

CHEETAH

RUGGEDIZED CAMERA SERIES

Front View

Rear View

C5410

CMOS 17 MP

GigE Vision® with Power over Ethernet (PoE)

Imperx: C5410

The POE-C5410 camera features the Sony Pregius IMX387 Global Shutter CMOS sensor with a native resolution of 5472 x 3084 in a 4/3" optical format delivering up to 7 frames per second with GigE Vision® Power over Ethernet (PoE) output. The Sony Pregius image sensor delivers outstanding sensitivity and excellent image quality. Imperx puts you in control by providing full access to raw data without corrections. Using the simple intuitive graphical user interface, you can quickly apply image corrections, if desired. The C5410's flexibility, image quality, and speed make it suitable for a broad range of diverse and demanding applications, but "one size doesn't fit all," and Imperx can help optimize the camera to your exact requirements.

Specifications

Feature	Description	Feature	Description
Output Interface	GigE Vision® with Power over Ethernet (PoE)	Strobe Output	2 strobes, programmable position and duration
Resolution	5472 (H) x 3084 (V)	Pulse Generator	Yes, programmable
Sensor	Sony Pregius IMX387 CMOS Color/Mono	Data Corrections	2 LUTs pre-programmed with Gamma 0.45, 2 LUTs pre-programmed with Negative LUT Bad pixel correction (static), Flat field correction
Sensor Format	18.9 mm (H) x 10.6 mm (V), 4/3" optical format	Lens Mount	F-Mount (default)
Pixel Size	3.45 microns square	Canon EF Mount	Optional, Active or Passive
Shutter	Global shutter (GS)	Supply Voltage Range	12 VDC (6 V – 30 V), 1.5 A inrush @ 12 V PoE (IEEE 802.3af / IEEE 802.3at)
Sensor Digitization	12-bit	Power Consumption	Typical: 5.4 W @ 12 V; PoE: 6.5 W – without enabled Canon controller, Max: 7.8 W; PoE (Max): 7 W – with enabled Canon controller
Frame Rate	7 fps (8-bit), 3.5 fps (10-bit/12-bit unpacked), 4.6 fps (10-bit/12-bit packed)	Camera Current	Typical: 450 mA @ 12 V
Dynamic Range	71 dB	Size - Width/Height/Length	60 mm (W) x 60 mm (H) x 56.5 mm (L)
Output Bit Depth	8, 10, 12-bit	Weight	475.7 g
Analog/Digital Gain	Manual, Auto; 0 dB – 48 dB, 480 steps	Vibration, Shock	20G/100G
Digital Gain	1x (0 dB) to 4x (12 dB) with a precision of 0.001x	Environmental	-30 °C to +75 °C Operating -40 °C to +85 °C Storage (-40 °C to +85 °C tested)
Black Level Offset	Manual (0 – 4095), Auto	Humidity	10% to 90% non-condensing
White Balance	Manual, Auto, Off	MTBF	TBD
Shutter Speed	76 µs to 16.0 s	Military Standard	MIL-STD-810G
Exposure Control	Off, Manual, External, Auto	Regulatory	FCC Part 15 Class A, CE, RoHS, UKCA
Regions of Interest (ROI)	2 ROI		
Binning	1x2, 2x1, 2x2 (Mono cameras only)		
Sub-sampling	1x2, 2x1, 2x2		
Trigger Inputs	External, Pulse generator, Software, Computer		
Trigger Options	Edge, Pulse width, Trigger delay, Debounce		
Trigger Modes	Free run, Standard, Fast		
External Inputs/Outputs	2 IN (OPTO, LVTTTL) / 2 OUT (OPTO, TTL)		

Imperx: C5410 Applications

The POE-C5410 incorporates a number of unique features tailored to reduce system complexity, maximize interface bandwidth, and expand the usable operational range.

Aerospace • Satellites • Surveillance • Ball Grid Array • Printed Circuit Board Inspection • Motion Analysis • Broadcast Television • Telepresence • Unmanned Aerial Vehicles • Machine Vision • Intelligent Traffic Systems • Aerial Imaging • Open Road Tolling Systems • Situational Awareness

Absolute Quantum Efficiency

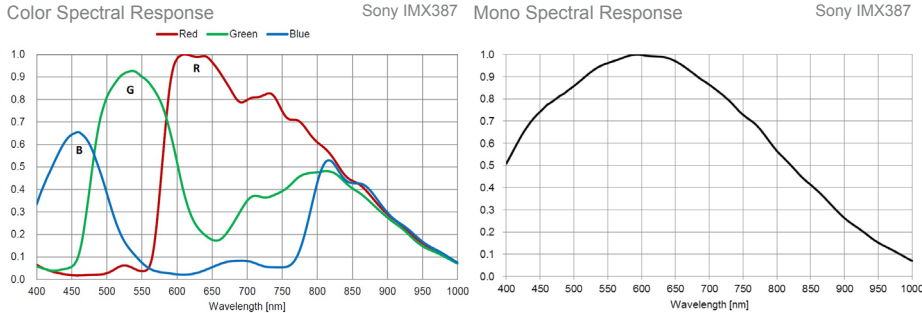

Dimensions

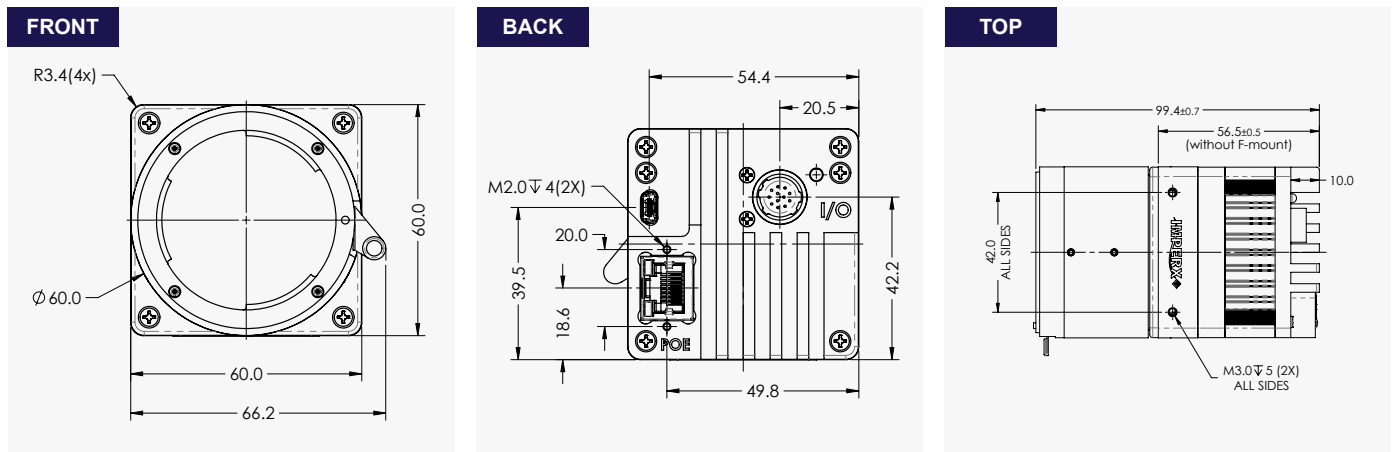

Ordering Information

Output Interface	Gen<I>Cam Compliant Camera Configurator
GenG Vision® with Power over Ethernet (PoE®)	
Sensor Types available	
Monochrome	
Bayer Color	
Lens Mounts	
F-Mount (Default)	
M42 (Optional)	
Canon EF Mount (Optional)	
Accessories (Sold separately)	
PS12V14A-Power Supply w/ 1 input and 1 output	

Gen<I>Cam Compliant Camera Configurator

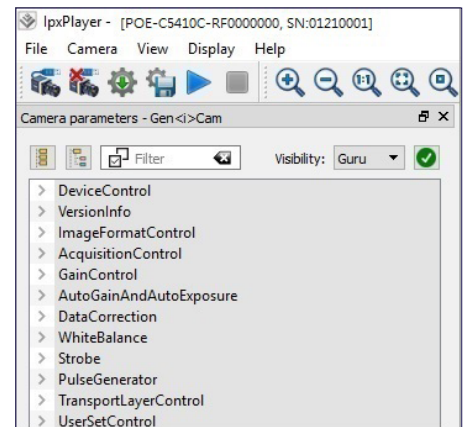

Hirose Connectors

Power and I/O Interface	
1. 12 VDC Return	7. OUT1 (TTL)
2. +12 VDC Power	8. IN1 (OPTO)
3. Reserved	9. IN2 (LVTTTL)
4. Reserved	10. IN1 RTN
5. OUT2 RTN (OPTO)	11. IN2 RTN
6. OUT1 RTN	12. OUT2 (OPTO)

Connector: Hirose HR10A-10R-12PB(71)

Rev: poe_c5410_r7_2021

Quality Management System ISO 9001:2015 Registered
Environmental Management System ISO 14001:2015 Registered
DDTC Registered (Directorate of Defense Trade Controls, US Department of State)



IMPERX 6421 Congress Ave., Boca Raton, FL 33487, USA
Tel: +1-561-989-0006. Email: sales@imperx.com

WWW.IMPERX.COM

Technical data has been fully checked, but accuracy of printed matter is not guaranteed. Subject to change without notice. Copyright 2021.

